

VDO KIENZLE

Montage- und Bedienungsanleitung
Installation and Operating Instructions

VDO
Ocean Line

Echolot
Depth Sounder

Contents

Preface	27
Safety Instructions	28
for installation	28
for maintenance	29
The VDO Depth Sounder.	30
System components	31
Accessories	31
Spare parts	31
The functions of the VDO Depth Sounder.	32
Basic calibration of the VDO Depth Sounder	33
Selection of the unit	33
Setting the keel depth	33
Setting and activating the shallow water alarm	34
Troubleshooting	36
Maintenance of the VDO Depth Sounder	37
Installation of the VDO Depth Sounder system	37
Installation of the indicating unit	37
Installation of the Depth Sounder	39
for internal installation	40
for through-hull installation	42
Electrical installation.	44
System power supply	44
Connection of a repeater	45
Circuit diagram legend	46
Cable lengths	46
Technical data	47

Manual should always be kept on board!

Preface

With the purchase of an instrument of the VDO marine program you selected a high-quality product, made to the accepted State of the Art. Advanced production methods and the respect of the applicable quality assurance standards guarantee that our products are shipped in excellent condition.

Thank you for your wise decision. We are certain that this system will provide you with valuable assistance and safety at sea.

You should be familiar with all functions of the system to guarantee easy and safe use of your VDO depth sounder.

Please take the time to study this manual completely.

Your VDO Kienzle agent will be pleased to help you, if you have any further questions or problems.

VDO Kienzle Vertrieb und Service GmbH

Safety Instructions

Please respect all instructions of this manual .

All texts marked with this symbol should have your particular attention. They are an indication of particular importance regarding the operation of the system and for your safety.



Good seamanship is essential! The use of the depth sounder does not relieve you of your responsibility for your ship. Always use your personal seafaring experience when interpreting the displayed values.

Safety Instructions concerning the installation

The system components should be installed by your shipyard or by a specialist.

Use adequate working clothes if you install the system yourself. Avoid loose clothing. Use a hair net if you have long hair. Clothing and hair can be caught by moving or rotating parts.

Remove all metallic or electrically conductive jewellery, such as chains, bracelets, rings, etc. when working on the on-board electronics.

Disconnect the minus polarity at the battery before starting work to prevent the risk of short-circuiting. Short-circuiting can cause cable harness fires, battery explosions and damage to other electronic systems. Please note that all volatile electronic memories will lose their contents, and will have to be re-programmed if you disconnect the battery. The VDO instruments are not equipped with volatile memories.

Risk of explosion! Run the engine compartment blower for a certain time before starting work in a gasoline engine compartment.

Check that there is enough space behind the installation opening. Pre-drill the opening and complete the opening with keyhole saw (respect the safety instructions of the hand tool manufacturer).

When selecting the location of the sending unit check that no stringers will be damaged and similiary furniture, floor boards, cables, etc.

Solvent vapours can be produced by the sending unit sealant. Provide sufficient ventilation. Respect the instructions of the sealant manufacturer.

Use insulated tools if you must work without disconnecting the power

supply.

The electrical outputs of the depth sounder indicating instrument and the connected cables must be protected against any direct contact or damage.

Capacitors in the unit can retain their charge, even if the unit is separated from its power supply.

The cables must have a sufficient insulation resistance or voltage rating, and touching the contact points should be prevented.

Electrically conductive parts of the connected loads must also be protected against direct contact by adequate measures. The use of non-insulated wires and contacts is strictly forbidden.

Safety Instructions concerning the maintenance

Repairs of depth sounder components may only be made by specialists authorized by VDO Kienzle. The VDO depth sounder system fulfills the applicable safety regulations.

VDO DEPTH SOUNDER

The VDO Depth Sounder

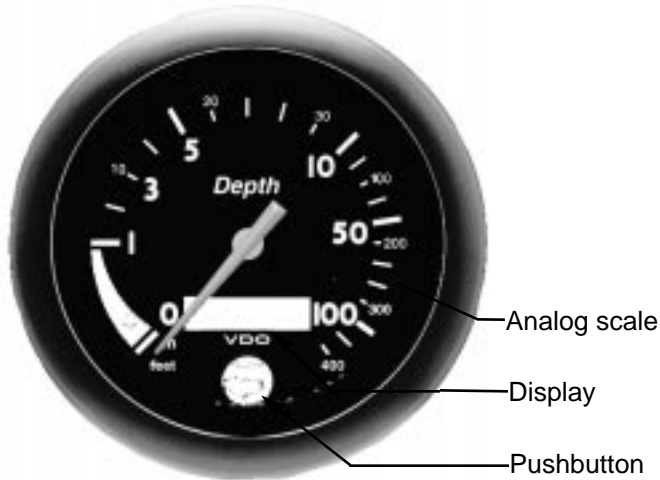

The VDO depth sounder is an advanced depth measuring instrument designed for sport navigation.

The pointer indicates the water depth below the keel in meters or feet on an analog scale when the system is active. This value is also shown as a digital value by the display in the lower dial section.

Alarm triggering is indicated by an integrated alarm buzzer. An additional external alarm buzzer can be connected.

The indicating unit has a front pushbutton for the necessary basic settings, and a shallow water alarm. Using the instrument is simple.

Up to two repeaters can be connected to the main instrument.

VDO DEPTH SOUNDER

System components

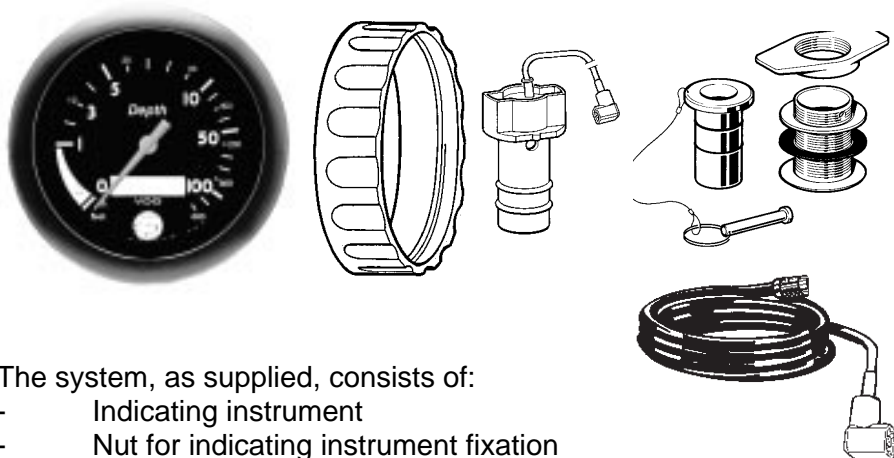

The system, as supplied, consists of:

- Indicating instrument
- Nut for indicating instrument fixation
- Echo sounder with cable, length 1 m
- Connecting cable between echo sounder and indicating unit, length 10 m
- Hull sleeve with sealing washers, fixation nut, retainer pin and rings (only for systems with through-hull echo sounder)
- Blind plug with control rope (only for systems with through-hull echo sounder)
- Installation and operating instructions

Accessories (not supplied with the system):

- | | | |
|---|--|-------------|
| - | Fixation parts kit (studs and bracket) | N05 800 792 |
| - | Illumination parts kit (24V /1.2W) | N05 800 550 |
| - | Repeater instrument VDO Depth Sounder | N01 410 702 |
| - | Alarm buzzer (12/24 V) | N03 230 702 |

Spare parts:

- | | | |
|---|--|-------------|
| - | O-Ring for depth sounder / blind plug (2x) | N05 801 418 |
| - | Illumination parts kit (12V / 1.2W) | N05 800 552 |

Other spare parts are available on request.

FUNCTIONS

The functions of the VDO Depth Sounder

Three bars are first displayed when the power supply is switched on, the pointer is at zero. Two whistling sounds are emitted.



After about 5 seconds the depth below keel is indicated as an analog value and displayed as a digital value (3.5 m in this example).

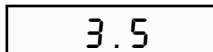

The analog indication shows the previous value if no ground echo can be obtained (see page 36). The display shows three bars, two whistling sounds are emitted.

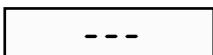

The display starts flashing. The pointer returns to zero and two whistling sounds are emitted if no ground echo is obtained during the next 15 seconds.

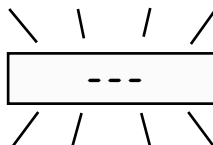

The display continues flashing until a ground echo is received again.

The display shows three question marks if the cable connection is not satisfactory or the echo sounder is defective. A continuous whistling sound is emitted. The pointer returns to zero.

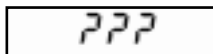

The acoustical alarm can be muted by activating the pushbutton. Check the connection of the indicating instrument to the echo sounder first. Defective contacts may have caused the alarm. If the alarm continues, although the connection is perfect, please contact your VDO agency.

BASIC CALIBRATION

Basic calibration of the VDO Depth Sounder

Selection of the unit Setting the keel depth

Keep the pushbutton pressed and switch the indicating instrument power supply on. Wait until the display shows „UNIT“.

UNIT

Release the pushbutton. The current unit setting (feet in the example) is displayed.

U FEET

Push the button to toggle between the units feet and meter.

U METER

About 5 seconds after unit selection the instrument prompts for the keel depth entry. The display shows „OFFSET“ and, shortly thereafter, the current keel depth setting (0.0 in the example).

OFFSET

05 0.0

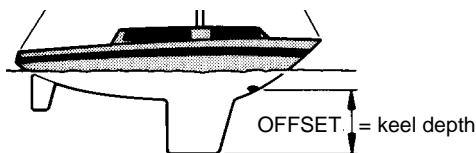

Push the button until the measured keel depth (1.2 m in the example) is set.

The value increments by 0.1 m or 1 foot at each press of the button. Incrementing is automatic if you keep the pushbutton pressed.

05 1.2

The setting range is 0.0 to 3.0 m or 0 to 9 feet.

The set value is stored if the pushbutton is not pressed for 5 seconds. After a double acknowledgement tone the depth is displayed automati-

BASIC CALIBRATION / ALARM

cally. The unit now displays the water depth below keel (4.6 m in the example).

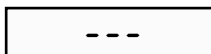

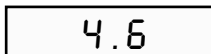

4.6

Setting and activating the shallow water alarm

In unsafe depths and in waters with unknown depths the alarm will warn you in time to avoid shallows and to prevent boat damages. The alarm setting range is 0 m to 120 m (0 to 396 feet).

The alarm can be switched off or on by double activation of the pushbutton when the display shows the current depth. The display shows the alarm threshold (0.0 m in the example) when the alarm is switched on.

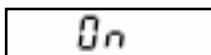

0n



0n 0.0

Set the desired alarm threshold by pressing the pushbutton. Up to 10 m (32 feet) the value increments by 0.1 m (1 foot), up to 120 m (396 feet) by 1.0 m (3...4 feet) per button activation. Continuous incrementation is obtained by keeping the pushbutton pressed.

After about 5 seconds after setting of the alarm threshold (0.9 m in the example) the display shows the current depth (2.7 m in the example), and the set value is stored.



0n 0.9

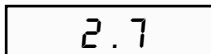

2.7

A continuous alarm is sounded if the depth below keel is less than the set alarm threshold (0.9 m in the example), and the flashing display shows the current depth measurement (0.7 m in the example).

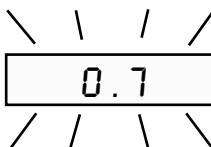

0.7

ALARM

The acoustic alarm can be switched off by pressing the button. It stops automatically when the depth below keel is greater than the set threshold.

The alarm function is deactivated if the button is quickly pushed twice when the current depth (2.7 m in the example) is displayed.

2.7

Push button

0n

Push button

OFF

2.7

Troubleshooting

Fault:

Cause and correction:

- | | |
|---|---|
| <ul style="list-style-type: none"> - No depth sounder function
 - Wrong indication
 - Display shows three bars
 - Display shows ??? | <ul style="list-style-type: none"> - Check electrical connections per wiring diagram. - Check supply voltage, 10.8 ... 32 VDC. - Check fuses in fuse box.
 - Check display unit selection. - Check keel depth setting.
 - No ground echo is received or evaluated correctly. - Check installation instructions for echo sounder.
 - Bad connection between sounder and display, Check the connections. |
|---|---|

The following causes may be the reason for a ground echo not being received or evaluated correctly:

- The maximum measuring range of 120 m is exceeded.
- The ground has a dense growth (seaweed).
- The ground is deep morasses.
- The water is severely polluted.
- Water layers of differing salt content or temperature, for instance in estuaries or sewage treatment plant outflows.
- Fish or fish shoals.
- The water contains air caused by preceding ships or by backing your own boat.
- Strong electromagnetic disturbances, for instance by refrigerator, motor, radio equipment, etc. .

TROUBLESHOOTING / MAINTENANCE

- Neighbouring ships also operating a depth sounder, for instance in a marina.
- The speed of the boat can also influence the measurement.

These examples show that even an optimum installation cannot eliminate all causes for temporary disturbances.

Maintenance of the VDO Depth Sounder

The indicating unit is maintenance-free. Use a humid, lint-free or antistatic cloth for cleaning. Do not use cleaning detergents.

At regular intervals (twice per season) check the two O-rings of the echo sounder and the 2 O-rings of the blind plug for wear, brittleness or damages. Even signs of the slightest wear require O-ring replacement.

Order number: N05 801 418 O-ring for echo sounder / blind plug (2x).

Installation of the VDO Depth Sounder system



Please read the safety instructions on pages 28 and 29 prior to the installation.

Installation of the indicating unit

- Drill a hole, 86 mm dia., at an suitable location.
- Clean the material and remove any chips before inserting the indicating instrument.

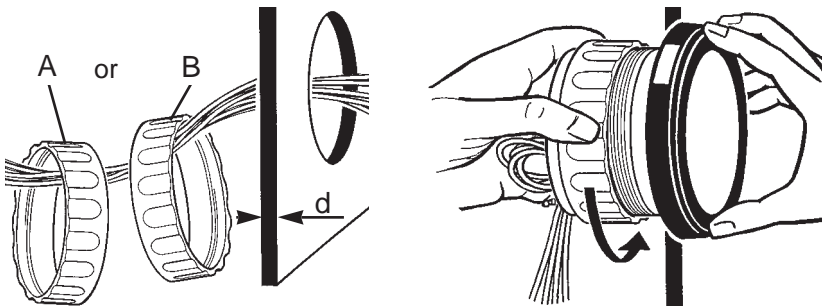

INSTALLATION

- Thread the indicating instrument cables from behind the mounting hole through the housing mounting nut.
- Place the supplied black rubber ring on the instrument back.
- Make the electrical connections of the indicating unit per circuit schematically (see „Electrical installation“) and insert the instrument into the installation hole.
- Secure the instrument by tightening the housing nut.
- At $d = 0.5$ to 6.5 mm, installation A.
- At $d = 6.5$ to 16.5 mm, installation B.
- The housing nut should only be tightened by hand.



Install the indicating instrument with stud and bracket (see below) if you expect strong vibrations at the location where the instrument is to be installed (e.g. high-speed boats).

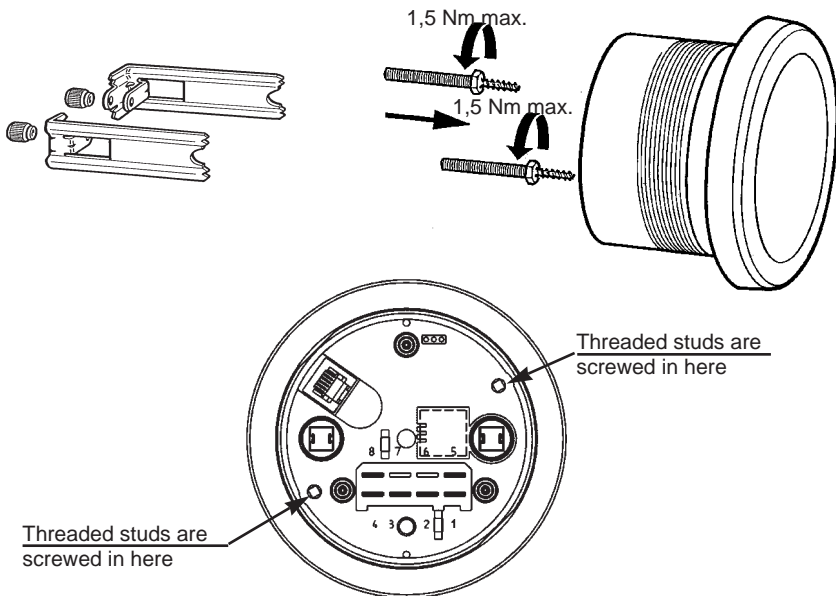

INSTALLATION

Installation of the Depth Sounder

The echo sounder unit must be installed in a turbulence-free zone in the hull. It should be mounted vertically.



Do not install the sending unit close to external valves, anodes, log sending units, etc. to avoid influences by turbulence.

Measure the distance between echo sounder and keel bottom and record this value. You will need it later on for the basic setting.

On sailing boats the installation should always be made directly in front of the keel, as close to the longitudinal axis as possible. On boats with a long keel the installation should be at the end of the first third of the hull, but not at the widest location of the hull.

A vertical installation of the echo sounder is especially important for sailing boats. If the installation is not vertical, it may be impossible to measure the depth, due to heeling of the ship.

Installation on sailing boats:

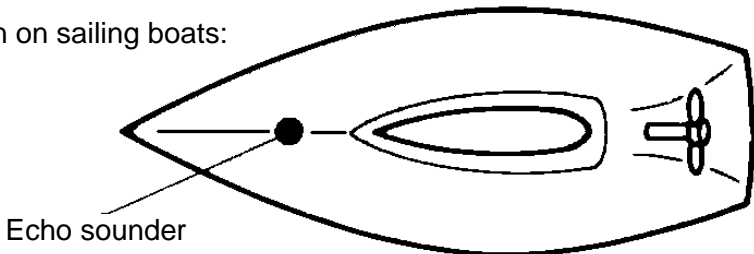

On powerboats the sending unit should be installed at about the beginning of the last third of the hull, never towards the stern, or in a zone of strong turbulence or up front, where strong disturbances by air introduction must be expected.

An ideal installation is near the longitudinal axis of the ship and in the zone of the first stringer directly in front of the engine compartment, if possible. At higher speed this is the only location where a disturbance-free echo sounder operation can be expected.

The deviation from the vertical should not exceed 10 degrees, but measurements may not be available at high speed, in tight curves and in deep water.

INSTALLATION

Installation on powerboats:

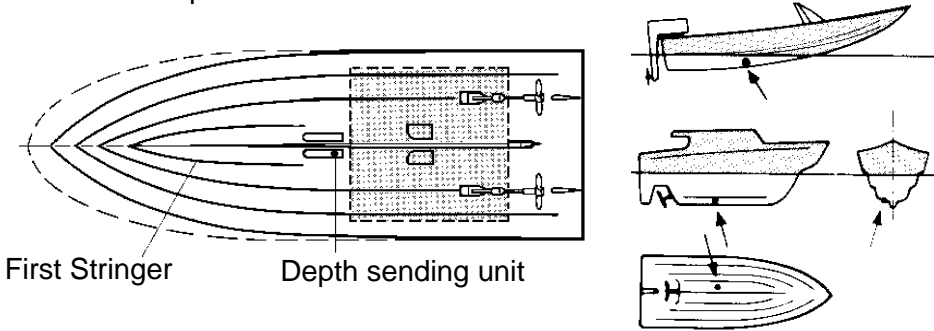

Installation of the echo sounder: internal installation

An internal installation of the echo sounder is only possible on ships with a fiberglass reinforced hull. This does not apply to fiberglass sandwich hulls.

Due to signal damping the internal installation may cause power losses, and is prone to more disturbances. Check that the location of the installation has no air inclusions in the laminate, and that the hull material thickness does not exceed 12 mm.



The ship must be in the water during the search for the optimum echo sounder location.

Proceed as follows in your search:

Supply the indicating instrument with power per wiring diagram (see page 44) and connect it to the echo sounder.

Put the sender in a plastic bag filled with water and move it over the hull until you obtain a stable depth reading.

Find the installation location:

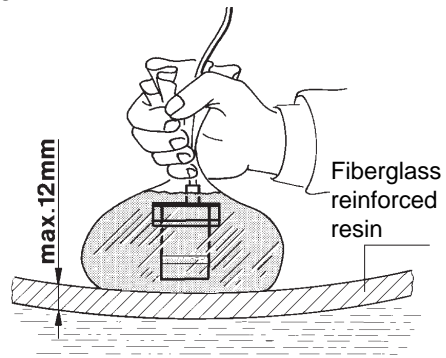

INSTALLATION

The echo sounder can be definitely fixed when you have found the optimum location.

Install the echo sounder by bonding it with a salt-water resistant sealant.

Install the echo sounder:

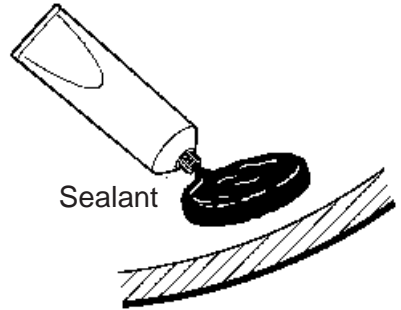

Fixation by sealant:
Avoid air bubbles between
echo sounder and hull.

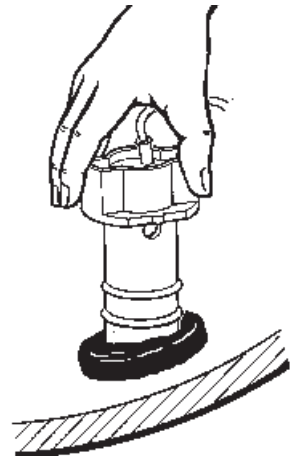

INSTALLATION

Installation of the echo sounder: through-hull installation

Make a hole, 53 mm diameter, at the selected location. The hull thickness should not exceed 36 mm.

Camber the hole out at 45 degrees for good sealant distribution and to obtain a reliable seal. Install the hull sleeve and the echo sounder as follows:

Hull sleeve installation:

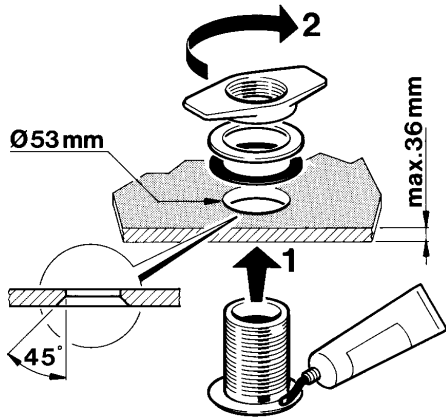

1. Put salt-water resistant sealant on the hull sleeve flange and insert the hull sleeve from the outside into the hole.
2. From the inside, install the black sealing ring on the hull sleeve, then the white one, and screw the fixation nut down. Lightly hand-tighten the fixation nut first. After letting the sealant harden, tighten the nut by hand and check the hull feedthrough for leaks.

Echo sounder installation:

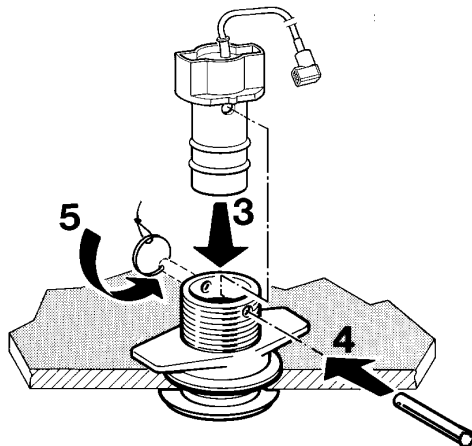

INSTALLATION

3. Insert the echo sounder into the hull sleeve and align the hole in the upper sounder section with the holes in the sleeve.
4. Secure the sounder by inserting the retainer pin through the holes.
5. Lock the retainer pin by installing the rings at both pin ends.

Tie the control rope of the blind plug to one of the retainer pin rings. You will need the blind plug to remove the sounder. In this case the blind plug must be secured in the same way as the sounder.



Please note that a considerable quantity of water can enter the ship while the sounder is being removed. Never remove the sounder with the ship in the water. Never pull on the cable to remove the echo sounder. Insert the blind plug after removal of the echo sounder.

The sounder can be covered with a thin coat of antifouling paint. This coat must be free of air bubbles, which would impair the echo sounder function.

INSTALLATION

Electrical Installation

System power supply

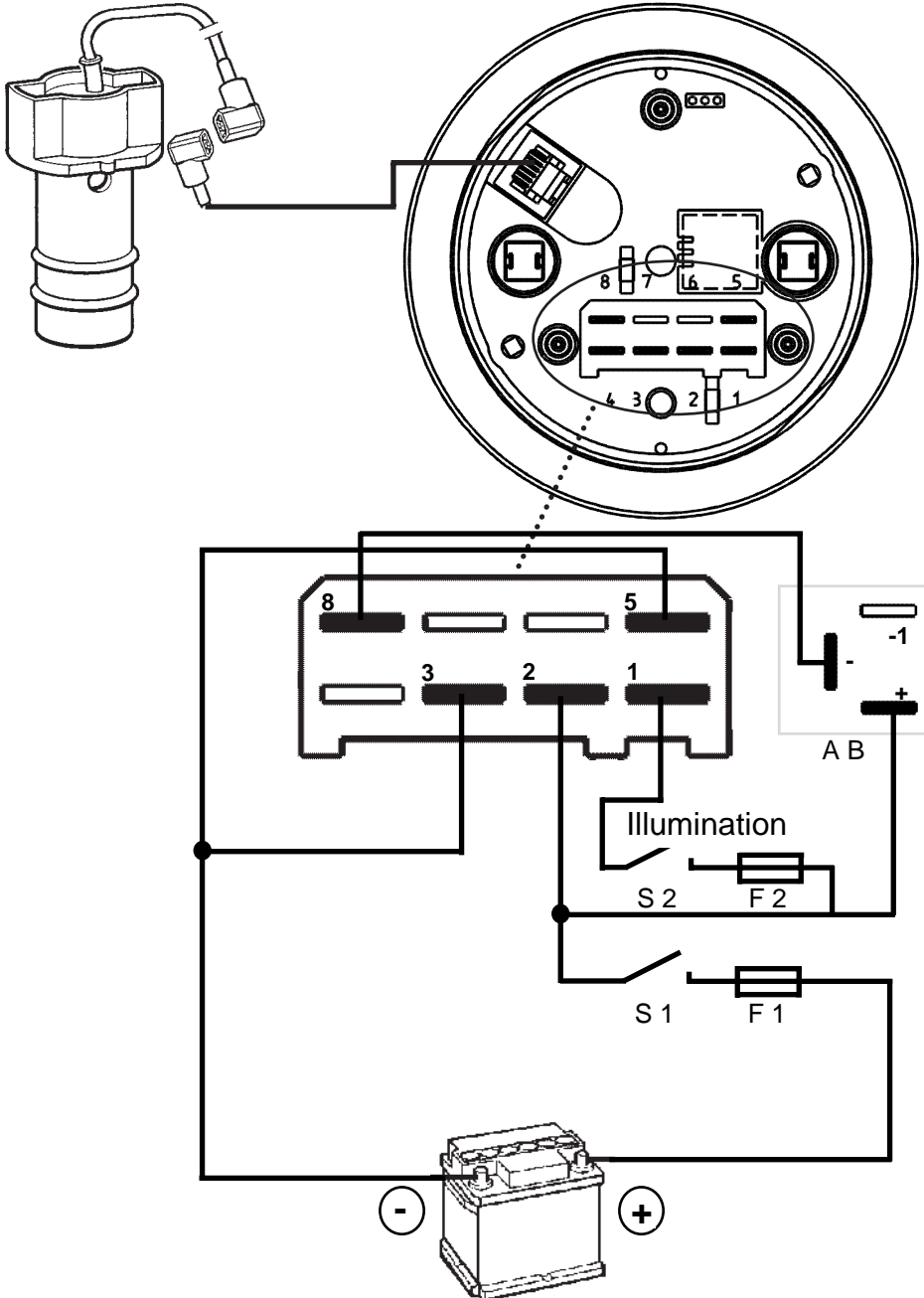

INSTALLATION

Connection of a repeater

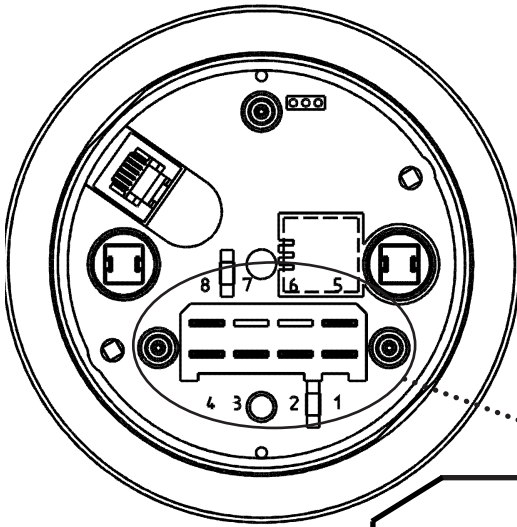

Main-unit

Make the power supply connection for the repeater the same as the main unit (see page 44). The connection between the main and the repeater, including the alarm buzzer, is shown in the diagram below.

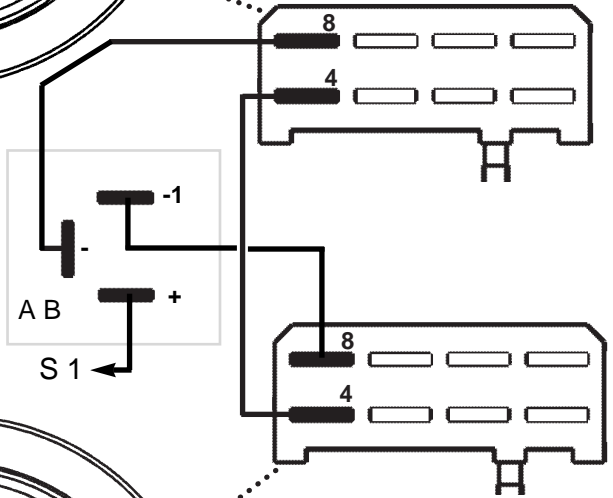

Repeater

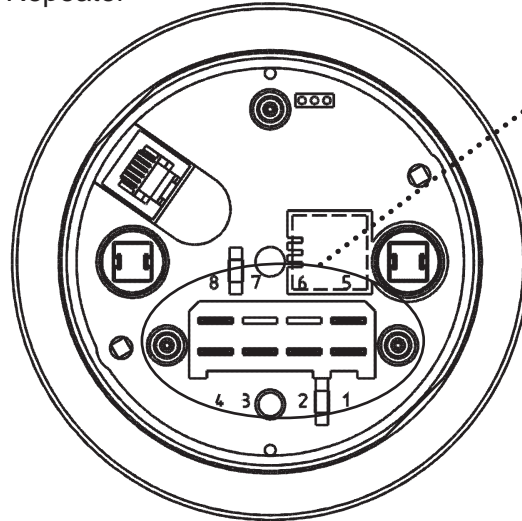

Note that the unit, keel depth and alarm must also be set (see page 33) on the repeater.

INSTALLATION

Advice on the connection of the alarm buzzer:

If the alarm is triggered by the main-unit, the alarm buzzer will send a permanent sound.

If the alarm is triggered by the repeater, the alarm buzzer will send an intermittent sound.

Circuit diagram legend

S1	On/Off switch for navigation instruments
S2	On/Off switch for instrument illumination
F1	Fuse for navigation instruments (5 A)
F2	Fuse for instrument illumination (5 A)
AB	Alarm buzzer (terminals)

Recommended cable section: 1.5 mm²

Cable lengths

Echo sounder - Indicating instrument:	20 m max.
Indicating instrument - Repeater:	10 m max.
Repeater 1 - Repeater 2:	10 m max.

Technical data

Measuring principle:	Ultrasonic running-time measurement
Application range:	0.5 to 120 m depending on ground and installation conditions
Frequency:	200 kHz
Supply voltage:	10.8 V ... 32 V DC
Current consumption:	Display unit: about 90 mA at 12 V DC without illumination, about 250 mA with illumination
	Echo sounder: about 50 mA at 12 V DC
Transmitter power:	about 40 Wrms, about 320 Wpp
Operating temperature:	-10 °C to +60 °C
Type of protection:	DIN 40050 - IP 65 at front, IEC 529
EMC protection:	CE: EN 50081-1, EN 50082-1
Dimensions:	Indicating instrument:
	Front ring diameter 105 mm
	Installation diameter 86 mm
	Installation depth 56 mm (union nut)
	Installation depth 90 mm (bracket)
	Sounder / Hull sleeve:
	Installation diameter: 53 mm
	Maximum hull thickness: 36 mm
	For internal installation:
	Maximum hull thickness: 12 mm

Technical modifications reserved



Echolot
Depth Sounder

09-97 -

08 601 103

VDO Kienzle Vertrieb und Service GmbH
Kruppstrasse 105
D-60388 Frankfurt am Main

Tel.: +49 (0)69 40805-0
Fax: +49 (0)69 40805-177
e-mail: vdomarine@vdokienzle.com
Internet: www.vdokienzle.com/marine